

www.gripkorea.com



HYDRO-y SET

Y axis adjust setting holder.

New!!

Hydro line-up



HYDRO-y SET

Easy and fast center correction function.



Guarantees the same run-out when changing tools with one setting.

Precision-always keep same run-out accuracy

Can be used with Hydro-sleeve.



OD8 type inner diameter $\phi 2 \sim \phi 6$
OD12 type inner diameter $\phi 3 \sim \phi 10$

HYDRO-y SET Easy Use.

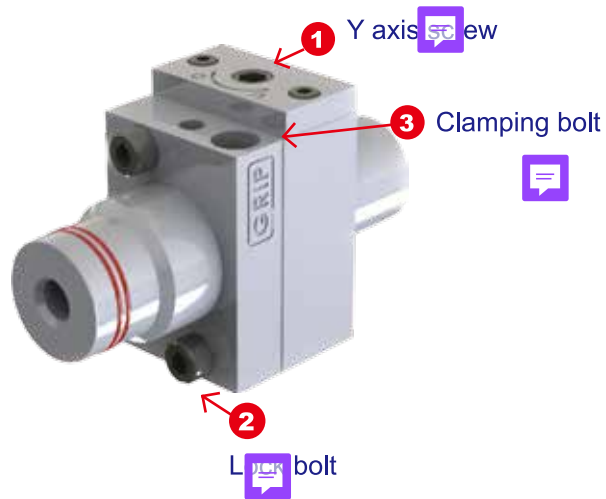

How to use

- 1step- **3** Clamp the tool to the Y-set holder and install it on the machine, then loosely tighten the **2** lock bolt.
- 2step- Run-out check.
- 3step- Adjust the center up and down with the **1** Y axis screw.
- 4step- Confirm the satisfactory center correction value and slowly tighten the **2** lock bolt completely.

Compatible with various machine brands.

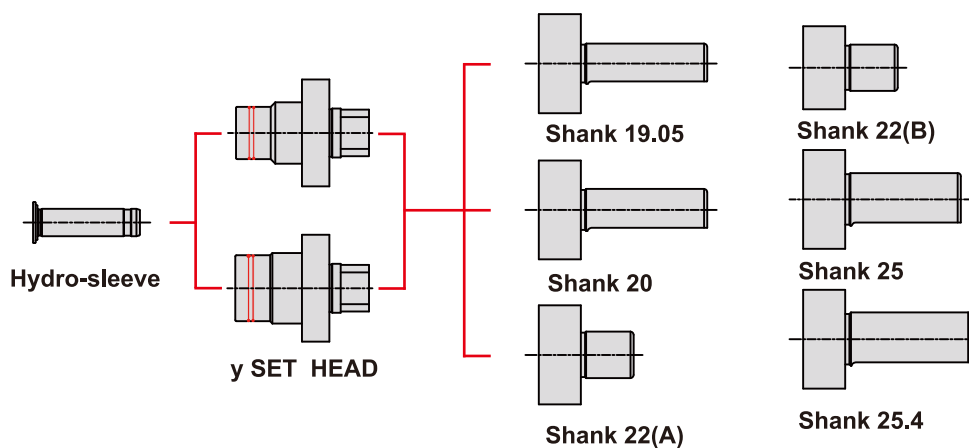

Back Type

≡ Dimensions(mm)

HEAD	D1	D2	D3	L1	L2	L3	L4	L5	Wrench	Type of machine
GYS-08(A)	8	23	27	15	28	29	51	12	TR-4.0	Use only for star machines
GYS-12(A)	12	29	31	15	31.5	29	52	12	TR-4.0	
GYS-08(B)	8	23	27	15	28	29	51	12	TR-4.0	Use for All machines
GYS-12(B)	12	29	31	15	31.5	29	52	12	TR-4.0	

- »h6 shank tools must be used.
- »T-wrench is must be ordered separately.
- »Can be used with various tools by using the hydro-sleeve.
- »All products center through coolant system.(All items Coolant M6x1.0)
- »Additional sizes and special designs available on request.
- »GYS-08(A) and GYS-12(A) head is only use for star machines.
- »The minimum tool depth must be observed.

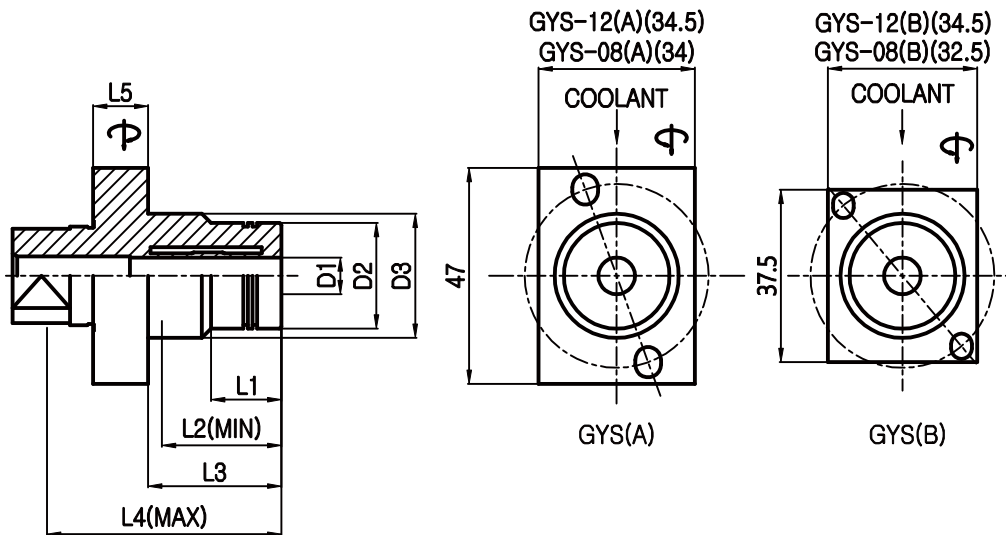

GYS-08 / GYS-12

Back Type

≡ Dimensions(mm)

SHANK	D1	L1	L2	L3	Type of machine	Y axis screw Wrench
ST19.05-SHK	19.05	80	60	20	Citizen/ Nexturn	TR-5.0 (5mm hexagon Wrench)
ST20-SHK	20	80	60	20	Tsugami / Tornos	
ST22(A)-SHK	22	45	25	20	Star	
ST22(B)-SHK	22	45	25	20	Star / Nomura	
ST25-SHK	25	75	55	20	Tsugami / Tornos /Hanwha	
ST25.4-SHK	25.4	80	60	20	Citizen	

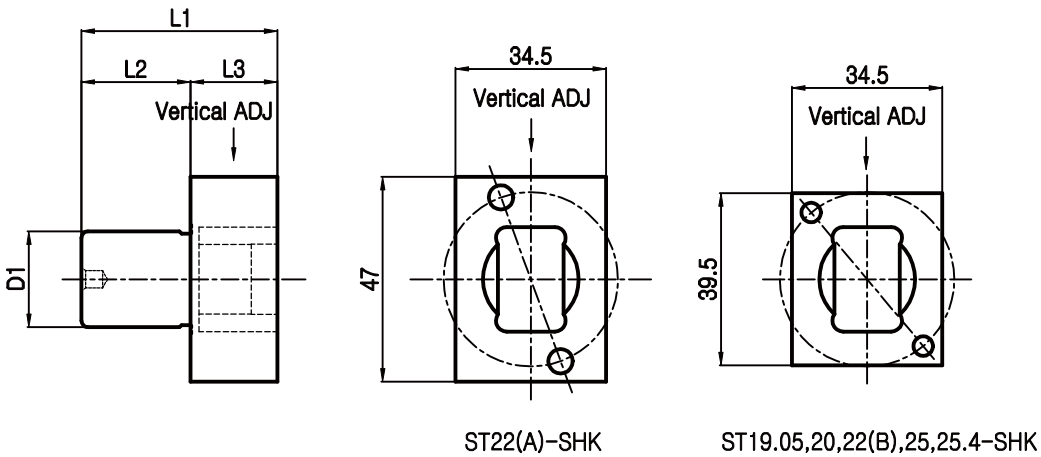

SHANK

