

# Special tools

## Series 311-xx°

Conical knurling  
Face knurling

Conical/inner/face knurling  
up to a shoulder



20° - 60°



90°

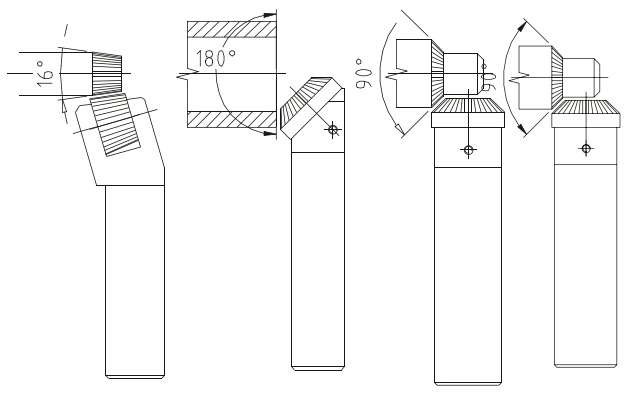

Knurling profiles on DIN 82 workpiece:

Plunge knurling



Selection of knurling wheels:



## Series 312-xx°

Conical knurling



1° - 60°

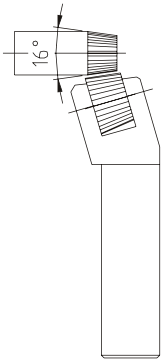

Knurling profiles on DIN 82 workpiece:

Plunge knurling

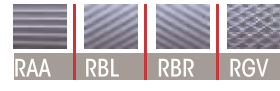

Selection of knurling wheels:



# Special tools

## Series 330

Knurling within a bore

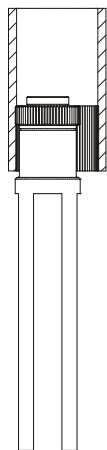

Knurling profiles on DIN 82 workpiece:

**Plunge knurling**



Selection of knurling wheels:



**Feed knurling**



Selection of knurling wheels:



## Series 332

Knurling within a bore up to a shoulder

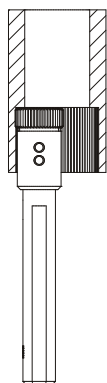

Knurling profiles on DIN 82 workpiece:

**Plunge knurling**



Selection of knurling wheels:



**Feed knurling**



Selection of knurling wheels:



## Series 342

Knurling within a bore up to a shoulder

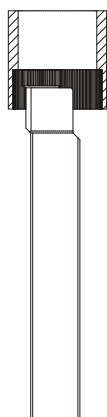

Knurling profiles on DIN 82 workpiece:

**Plunge knurling**



Selection of knurling wheels:



**Feed knurling**



Selection of knurling wheels:

